

AERZEN POSITIVE DISPLACEMENT BLOWERS



AERZEN

**AERZENER MASCHINENFABRIK
GMBH**

G1-001 | 11 | EN

3000

11.2004

Aerzen Positive Displacement Blowers

for the oil-free conveying and compression of air and gases

Aerzen Positive Displacement Blowers (of the „Roots“ type design) have been manufactured since 1868 and today are highly developed standard production machines designed and adapted to find use in a wide variety of applications.

The following are only a few examples of the many applications in which Aerzen Blowers can be used:

- **Pneumatic conveying of bulk materials in suction - or discharge pressure**

Machine sizes range from small blowers installed in tank vehicles to very large ones used in pneumatic elevators for vacuum operated ship unloaders. The hourly capacity of such unloading installations is up to 1000 tons at present.

- **Pressurized aeration of basins in sewage treatment plants**

- **Filter flushing blowers in drinking water production plants.**

- **High vacuum boosters**

are equipped with special shaft seals.

- **Conveying of practically all gases**

found in the chemical, petrochemical, and metallurgical industries. Special designs are available to handle aggressive gases. Machines used in both conventional and nuclear power plants comply with the various categories of safety regulations.

- **Gas boosting blowers**

rated for internal static pressures of up to 25 bar.

- **Steel production**

Application in direct-reduction plants.

Oil-free conveying

The fact that Aerzen positive displacement blowers convey the medium oil-free is a decisive advantage in pneumatic conveying, in water filtration plants, and in the food and chemical industries. Since the rotary pistons revolve without making contact with each other and the housing, no lubrication is required in the conveying chamber, which guarantees that the medium conveyed remains free of contamination from lubricants and wear particles.

Conveying based on the positive displacement principle

The inlet flow volume varies only slightly in response to changes in back pressure. Blower output can be adapted in the swept volume to the operating conditions simply by varying its speed.

Wide range of selection

The extensive number of models and sizes available facilitates the selection of the optimal machine for any given application. Machines handling capacities ranging from approx. 30 m³/h to approx. 84000 m³/h in either vertical or horizontal flow configuration can be supplied.

Drive types

Blowers are driven by electrical motors, internal combustion engines, hydraulic or compressed air motors via flexible coupling (arrangement 4, DA), flanged motor B 5 (for HV - blowers). V-belt drive (arrangement 5, FA) Reducer drive, shift gear transmission or variable speed drive (arrangement 6, 6 h)

High mechanical efficiency

Since the rotary pistons revolve without making contact, mechanical power losses are generated in the bearing and timing gear assemblies only. The use of ball and roller bearings as well as tempered and ground timing gears reduces these losses to an absolute minimum. Furthermore it is advantageous that the helical gearing offers a running of low noise.

High volumetric efficiency

The rotary pistons and casing components are manufactured using modern CNC-controlled precision machine tools, guaranteeing exact tolerances even in the large scale production of standard components. This is reflected in the minute clearances both between the rotors as well as between the rotors and the housing, resulting in very high degrees of volumetric efficiency.

Operating reliability and safety

Aerzen positive displacement blowers are produced by highly skilled and experienced professionals, and are not delivered prior to having been thoroughly tested. Each and every blower is subjected to a test run lasting several hours under conditions of increased load. A test record is prepared with all data which will still be available years later.

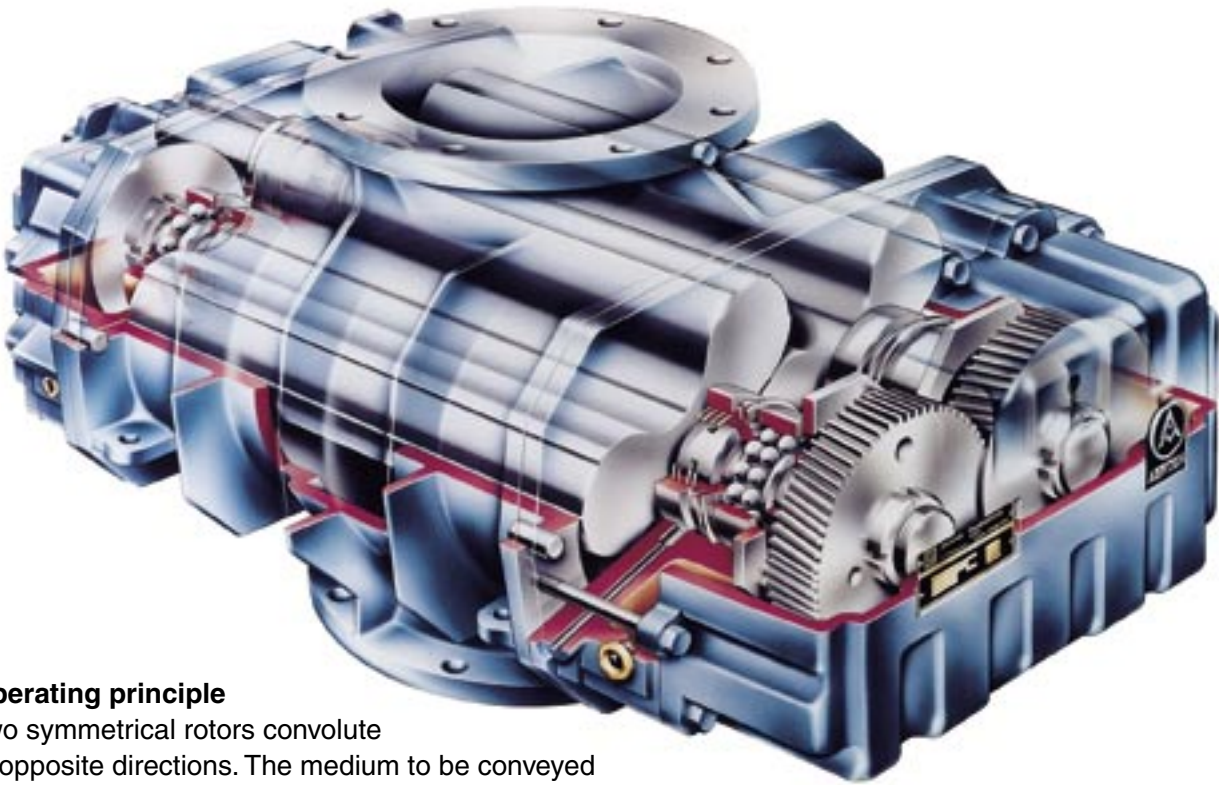

Operating principle

Two symmetrical rotors convolute in opposite directions. The medium to be conveyed flows into the housing surrounding the rotors, and is displaced in a positive manner from the inlet to the discharge side via the chambers formed between the rotors and the housing. At the very moment the rotor tip clears the edge of the pre-inlet channel, the volume of the gas displaced is compressed by the backflow of the pressurized gas present in the conveying piping at the discharge socket. The final pressure automatically adjusts itself to the pressure level in the downstream piping and components. The flow required to convey all types of gases under various operating conditions can be calculated once specific blower data are known. Each rotor revolution results in the displacement and compression of the so-called scoop volume q_0 (litre/revolution). The scoop volume shows a constant for each blower size. This results in the theoretical capacity

$$Q_0 = \frac{n \cdot q_0}{1000} \text{ (m}^3\text{/min)}$$

The actual capacity is obtained by deducting the amount of gas Q_v slipping back through the clearances from the theoretical capacity:

$$Q_1 = Q_0 - Q_v \text{ (m}^3\text{/min)}$$

The amount of slippage through the clearances depends on the density of the gas at the inlet, the differential pressure Δp and the total area F of the clearances.

The volumetric efficiency is

$$\eta_v = \frac{Q_1}{Q_0} = 1 - \frac{Q_v}{Q_0}$$

Since the rotor clearances are kept to a minimum, efficiency under operating conditions is highly favourable. The output volume varies very slightly with changes in load (see page 4).

The power required to compress the flow at inlet conditions is, theoretically:

$$P_{th} = \frac{Q_0 \cdot \Delta p}{600}$$

This power must be increased to compensate for the mechanical friction in the bearings, timing gears, seal components, as well as in the dynamic losses occurring in the blower nozzles and the conveying chamber.

The power required at the blower coupling is:

$$P_k = P_{th} + P_v \text{ (kW)}$$

The main component i.e. the theoretical power for compression, is thus independent of the type of gas involved, and directly proportional to both the operating pressure differential and the blower speed. Since no internal compression takes place, the power absorbed when operating without load is nearly equal to the power loss P_v .

This represents approximately 3 to 5 % of the full load power rating transmitted via the coupling.

Due to the sum of all manufacturing tolerances, power consumption and intake volume flow can show a tolerance of ± 5 %.

Volumetric performance curves of a positive displacement blower

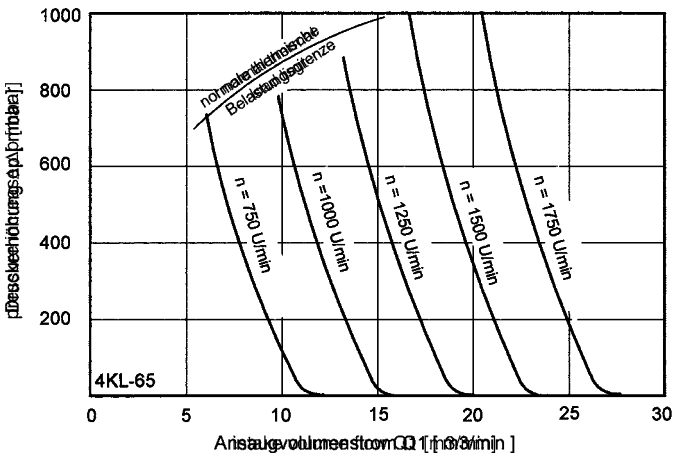

Noise behaviour

Due to more and more severe environmental requirements further noise reduction for positive displacement blowers and other machines is necessary. If these are pure machine noises it is relatively simple by using acoustic hoods.

But in case the sound input, led through the conveying flow into the piping, has to be reduced, only two possibilities remain:

1. secondary measures
2. primary measures

Silencers, pulsation silencers, sound insulation of the piping etc. are costly secondary measures.

For good reasons the Aerzener Maschinenfabrik has decided for the primary measures i.e. to reduce noises already in their origin. Therefore the 3-lobe blowers have been developed.

The goal was attained by the development of positive displacement blowers with integrated pulsation reduction. The blower-cylinder was equipped with so-called pre-inlet channels of which type, size and position have been determined experimentally. Together with the 3-lobe rotary pistons an essentially softer opening to the discharge side will result and the usual back flow pulse reaches the conveying chamber only considerably weaker (see blower-symbol on right of page).

But there is still a second noise source within blowers. It is the so-called squeezing pulse which arises when the piston head of one piston dips into the depression of the other one. Due to the position and shaping of the pre-inlet channels the phase position and amplitude can be connected so that they extinguish each other.

In practice this can naturally not be reached by 100 %. However attempts have shown that a reduction of the noises by up to 20 dB(A) is attained.

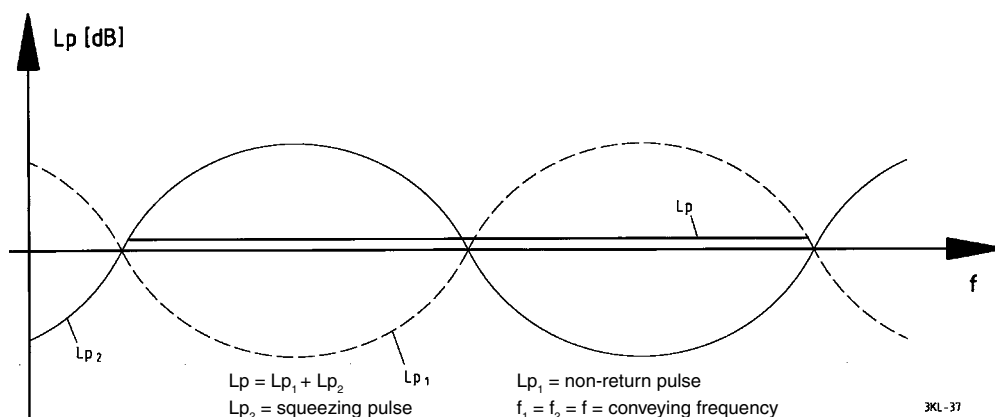
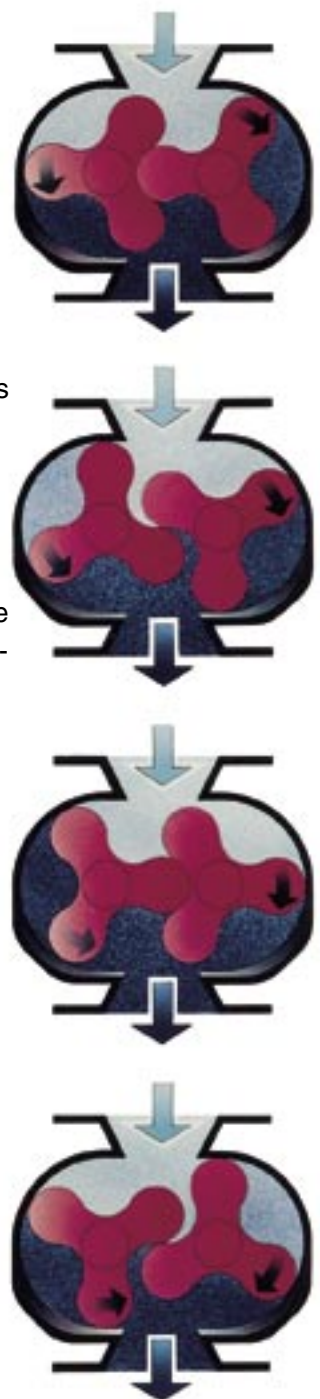

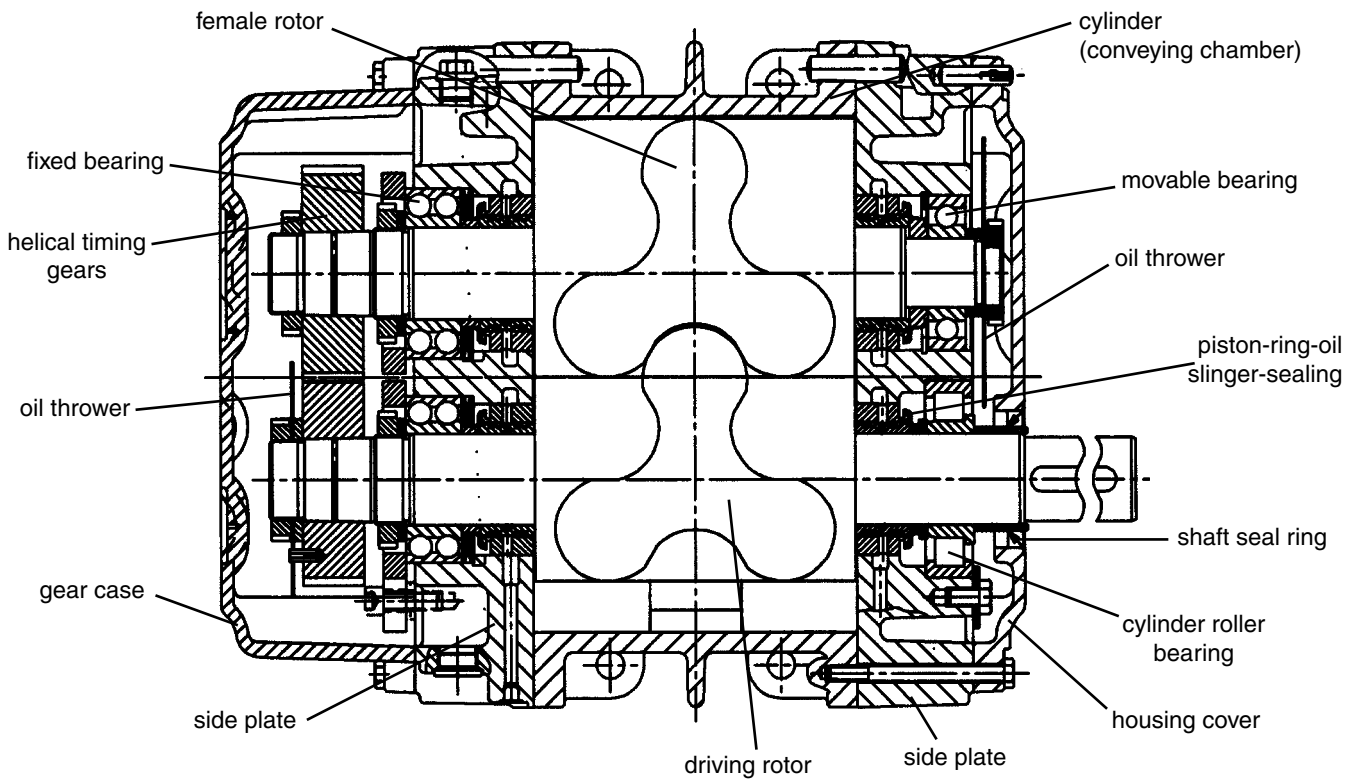

Aerzen Positive Displacement Blower of the series GM
Sectional view of the blower GM . . .

Design and construction

Aerzen positive displacement blowers are twin shaft rotary machines. The two rotors are placed axially parallel to each other and centered within the housing. Timing gears ensure that the rotors revolve without making contact. The rotors are supported on ball and roller bearings. In order to achieve a high efficiency the clearance between the rotors is kept to a minimum and is based on the pressure differential and thermal load expected under operating conditions. In case of larger blowers the roller bearing clearances and the shaft deflection have an influence on the clearance. Larger clearances between the rotors and the end plates compensate for axial thermal expansion at the floating bearing end.

Rotors

The rotors are dynamically balanced. Smaller blowers of the sizes GM 3 S - GM 80 L feature steel rotors and shafts (C 45 N), drop-forged in one single piece. Sizes GM 90 S and larger are constructed with pistons made of modular cast iron and steel shafts (C 45 N). Where contamination particles are likely to accumulate during operation, the cavities of the cast iron rotors are capped.



Housing

The housings are made of high quality grey cast iron (GG 20). **The blower housing requires no additional cooling, even at high loads.** Up to the size GM 80L, the blower feet are bolted on.

Timing gears

The helical timing gears are tempered, and then ground to an exacting degree of precision. The positioning and fastening of the gears onto the shafts takes place via taper interference fit, guaranteeing both excellent concentricity and reliable adherence.

Special materials

Non-standard materials such as nodular graphite cast iron (GGG 40), cast steel (GS - C 25) and CrNi - cast steel are available for special applications. Special requirements, however, must be clarified with the manufacturer in advance!

Sealing configuration, serie GM

These models are designed to convey air or neutral gases. The conveying chamber is sealed from the oil chambers by means of an oil slinger in conjunction with piston ring labyrinth type seals featuring a generously dimensioned central vent chamber (condensate channel), and which plays a crucial role in ensuring that the medium conveyed remains clean and oil-free. The drive shaft is sealed by means of a radial seal ring installed in the housing cover.

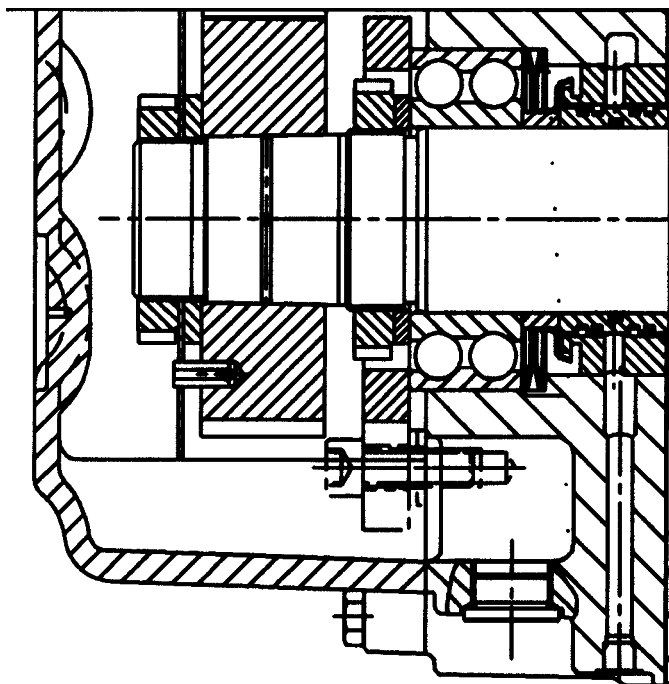

Special designs:

Double oil-purged radial seal rings at gas conveying. Double-oil-purged radial seal rings with shaft sleeve and air-cooled seal ring housing (from profile 18 cooling water channel) are used in high vacuum designs. A double-acting mechanical seal with a seal oil circulation system for applications involving pressure-tight housings rated for static internal pressures of up to 25 bar.

Sealing configuration, gas blower series GRa, GRb and GR

These models feature bearing housings which are outboard of the conveying chamber. The four shaft passages at the conveying chamber are sealed from atmosphere by means of double-acting mechanical seals, which are either water- or oil-purged and cooled, or by labyrinth type packing. These machines are also available with soft packing seals.

Sealing configuration, gas blower series GQ

The four shaft passages at the conveying chamber are sealed by means of special mechanical seals.

Lubrication

Positive Displacement Blowers are splash lubricated. The oil thrower discs and timing gears carry the lubricant to the ball and roller bearings. In special cases where splash lubrication is inadequate as a result of high operating speeds or operating temperatures requiring oil cooling, or where an oil recirculation system is required in conjunction with oil-cooled mechanical seals, a central forced oil lubrication system is supplied (refer to the operating instructions for oil grades).

Drawing cutout:
Oil sealing to conveying chamber,
adjusting bearings, helical timing gears

Aerzen Positive Displacement Blowers in standard design

3-lobe positive displacement blowers type GM
intake volume flow approx. 30 to 65.000 m³/h

22 sizes GM 3 S to GM 1080 L

Fields of application

Oil-free conveying of air and neutral gases.
Operating pressure up to max. 1000 mbar gauge.
Suction operation: up to max. -500 mbar gauge.

Design

Blower with 3-lobe rotors and two cast-in pre-inlet channels in the discharge-sided cylinder part to minimize the sound by pulsation reduction.
Housing ribbed and air-cooled.
Blower cylinder undivided up to GM 400 L.
From GM 430 S the cylinders are horizontally divided.
Up to GM 80 L the feet at the blower are bolted on, larger sizes are cast on.
Lube oil supply by splash lubrication.

Materials

Housing parts (cylinder, side plates, gear case and housing cover) made of GG-20. Shafts made of C 45 N and rotors made of C 45 N (GM 3 S up to GM 80 L) shafts and rotors are forged in one piece.
On size GM 90 S and GM 130 L pistons and shafts are cast of one piece EN-GJS-500-7 (GGG50). Rotors made of EN-GJS-400-15 (GGG40). (GM 150 S up to GM 1080 L) helical timing gears made of 16 Mn Cr 5E.

In case other materials are needed, please ask for!

Shaft sealings

Conveying chamber seal by 4 piston ring labyrinth seals with oil slingers at each shaft end.
On request, 4 radial seal ring-piston ring-labyrinth seals are available.
Driving shaft seal by radial seal ring.
In case of gastight design of the driving shaft 2 radial seal rings are used with an intermediate grease trap.

Direction of flow

from top to bottom (vertical)

Position of the driving shaft

left (viewed onto the driving shaft)
alternatively the driving shaft is possible at the right

Drive

Overhung drive via narrow v-belt, directly driven via flexible coupling or with gearbox.

Regarding further details please see leaflet G1-066.
If required, please ask for.



GM 3 S



Aerzen Compact Blowers (units) in standard design

type DELTA BLOWER
type Compact Blower I/3

16 sizes

intake volume flow of approx. 30 to 15.000 m³/h

intake volume flow up to approx. 20.000 m³/h

Fields of application

Oil-free conveying of air and neutral gases.

Operating pressure up to 1000 mbar

Suction operation up to - 500 mbar.

Drive

overhung via narrow v-belt

Unit design

The blower units comprise all necessary standardized accessories required for trouble-free operation, are fully assembled and ready for installation at site.

Due to the integrated pulsation reduction disturbing pulsations are already reduced at their source. Therefore a costly silencing is no longer necessary.

All components of the unit are installed resp. mounted on the base support.

The base support includes purely metallic installations completely free from wear with which a uniform sound reduction over the whole speed range can be achieved.

The driving motor is mounted on a hinged support via narrow v-belt. This conception ensures that the belts are always optimally tensioned and also after a longer operating period no retensioning is necessary.

A flexible installation is standard.

Special foundations are not necessary.

Flexible connection of the pressure piping.

Scope of supply DELTA BLOWER in standard design

- 3-lobe blower stage with integrated pulsation reduction
- base support with integrated discharge silencer
- hinged motor support as tensioning device for the belt drive
- set of flexible anti-vibration mountings
- intake silencer with integrated air filter
- belt drive with guard
- pressure-/suction valve
- connection housing with installed non-return flap and connection flange for pressure valve and start-up unloading device
- flexible connection with clamps

Accessory components as option:

- Driving motor (three phase a.c. motor)
- Acoustic hood
- Start-up unloading device (necessary in case of star-delta-starting of the driving motor)
- Pressure gauge (for indication of the conveying pressure)
- Maintenance indicator (for monitoring of the intake filter)
- Switch cabinet

If further accessories are required, please ask for!

Regarding the technical design of the blower stages please see page 7.

Our leaflet G1-066 informs you about performance data as well as a detailed description of the individual components. If required, please ask for!



DELTA BLOWER

Unit sizes GM 3 S up to GM 240 S



Description: unit GM...
without acoustic hood / with acoustic hood



Aerzen Bulk Vehicle Blowers

Type GM 4 sizes intake volume flow 600 up to 2.250 m³/h

Design with 3-lobe rotors

Cylinder with cast-in pre-inlet channels at discharge side to minimize the sound by pulsation reduction. Therefore only vertical installation position is possible. Speed range between 1450 up to 4800 1/min. Oil splash lubrication with oil sight glasses on both sides.

Shaft sealings

Conveying chamber by the carbon ring labyrinth seal proven over decades in connection with the neutral chambers open to atmosphere. Driving shaft with radial seal ring.

Direction of flow

vertical, from top to bottom

Fields of application

Conveying of air.
Operating pressure up to 1000 or 1200 mbar peak pressure.
Suction pressure up to -500 mbar.

Design: with two-lobe rotors

The conveying chamber is completely separated from the oil sumps by a space open to atmosphere. The machine can be positioned upright, suspended from the top, and suspended from the left or right. They are also available with an integrated gearbox with a speed step-up ratio of $i = 2,1$. The operating speed range is 1350 to 3200 1/min. The drive side is grease lubricated, while the gear side is splash oil lubricated. Gear driven models feature splash oil lubrication on both sides. Oil level check by means of dipstick.



GM 25 S
GM 35 S

Shaft sealings

The conveying chamber is sealed by means of four piston rings in combination with oil slingers adjacent to the vent space. The drive shaft is sealed by a seal ring. Gear driven models are sealed by a radial seal ring.

Direction of flow

Both directions possible in horizontal or vertical flow.

Drive

Via direct coupling or narrow v-belt drive.

Special materials

None available.

For detailed information refer to leaflet G1-071 or brochure G1-066.



GM 13.5



GM 13.f7

Aerzen High-Pressure Blowers

Type GM...dz housing compression-proof for PN 25 5 sizes intake volume flow 60 up to 6.000 m³/h

Fields of application

Conveying of air and neutral gases.

Operating pressure range up to max.

$P_e = 25$ bar gauge where the medium has the corresponding inlet pressure.

Max. differential pressure 2000 mbar.

Design

Housing with circular flanges and o-ring seals, lube- and purge oil supply by complete oil unit, oil chambers under gas pressure.

Shaft sealings

Conveying chamber by combined oil slinger piston ring labyrinth seals with condensate chamber between the piston rings or shaft seal ring - piston ring labyrinth seal.

The drive shaft is sealed via compressed-oil-purged double-acting mechanical seal.

Direction of flow

Vertical, from top to bottom.

Drive

Direct coupling with motor or via flexibly coupled spur gear.

Booster-design

- Type GM...d
- Max. pressure increases of 1,0 bar abs. to 2,0 bar abs.
- Housing compression-proof for PN 25 with o-ring sealings
- Splash lubrication
- Driving shaft seal by 2 shaft seal rings with grease trap
- Drive direct via flexible coupling or overhung via narrow v-belt

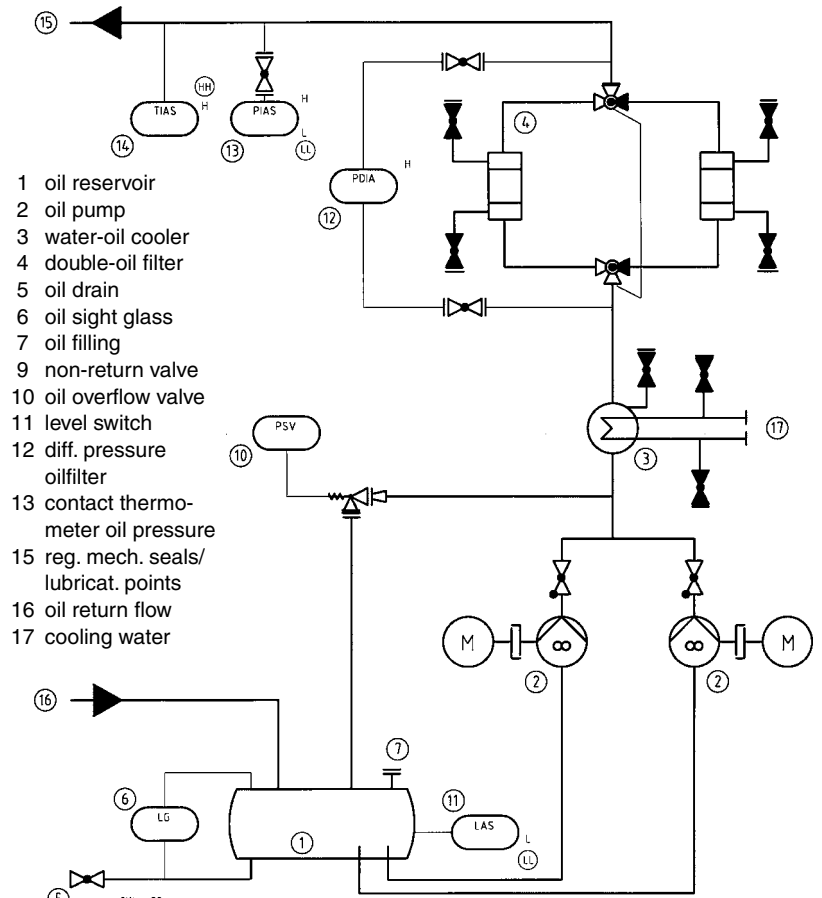

oil supply unit

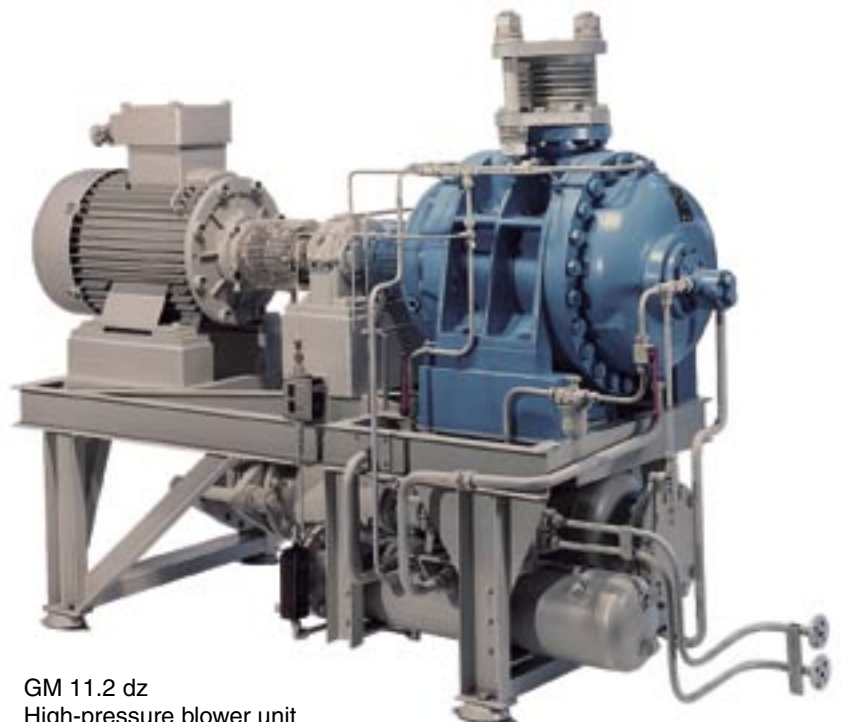

GM 11.2 dz
High-pressure blower unit
with compressed-oil lubrication

Aerzen Process Gas Blowers I

Type GR/GRa/GRb 12 sizes intake volume flow 100 up to 50.000 m³/h

Fields of application

Conveying of industrial gases which may also be aggressive.

Overpressure - and vacuum range

Differential pressure at pressure operation up to 800 mbar

Differential pressure at suction operation up to 450 mbar

Design

The conveying chamber is completely separated from the oil sumps by a space open to atmosphere.

Shaft sealings

Conveying chamber sealed by

- a) pressure relieved soft packings with purge gas connections,
- b) pressure relieved carbon ring - labyrinth seals with purge gas connections,
- c) double-acting mechanical seals, oil-purged
- d) double-acting mechanical seals, water-purged.

Drive shaft by radial seal ring.

Direction of flow

Vertical, from top to bottom.

Drive

Direct via flexible coupling or via flexibly coupled spur gear.

Overhung via narrow v-belt (up to 250 kW driving power).

Special materials

Depending on the particular operating conditions, models are also available in CrNi cast steel or with different coatings.

For detailed data refer to leaflet G1-151.



GRa 12.4 and 13.6
GRb 14.8 up to 16f13



GR 17.14 up to 21.22

Aerzen Process Gas Blowers II

- | | | | |
|------------------------|---------|--------------------|---------------------------------------|
| 1) Type GQ . . . xz | 4 sizes | intake volume flow | 2.000 up to 100.000 m ³ /h |
| 2) Type GR/GQ . . . xz | 2 sizes | intake volume flow | 10.000 up to 32.000 m ³ /h |

Fields of application

- 1) Especially used in direct reduction plants for conveying of process - and cooling gas. Operating pressure range up to max. $p_e = 2,5$ bar where the medium has the corresponding inlet pressure. Max. pressure difference 1100 mbar.
- 2) Especially used in direct reduction plants for conveying of process - and cooling gas. Operating pressure range up to max. $p_e = 6$ bar where the medium has the corresponding inlet pressure. Max. pressure difference 1500 mbar.

Design

- 1) Housing compression-proof for PN 2,5
Cylinder with noise reducing chamber on the discharge side, housing with connections for water injection - and water flushing, as well as for lubrication - and purge oil supply systems.
- 2) Housing compression-proof for PN 6
Cylinder with noise reducing chamber on the discharge side, housing with connections for water injection - and water flushing, as well as for lubrication - and purge oil supply systems.

Shaft sealings

Conveying chamber by single-acting oil-purged mechanical seals in combination with labyrinth seals.

Drive shaft is sealed by 3 radial seal rings.

Direction of flow

- 1) Horizontal
- 2) Vertical or horizontal

Drive

- 1) Either via flexibly coupled spur gear or direct coupling with drive motor
- 2) Via flexibly coupled spur gear.

For detailed data refer to leaflet G1-151.

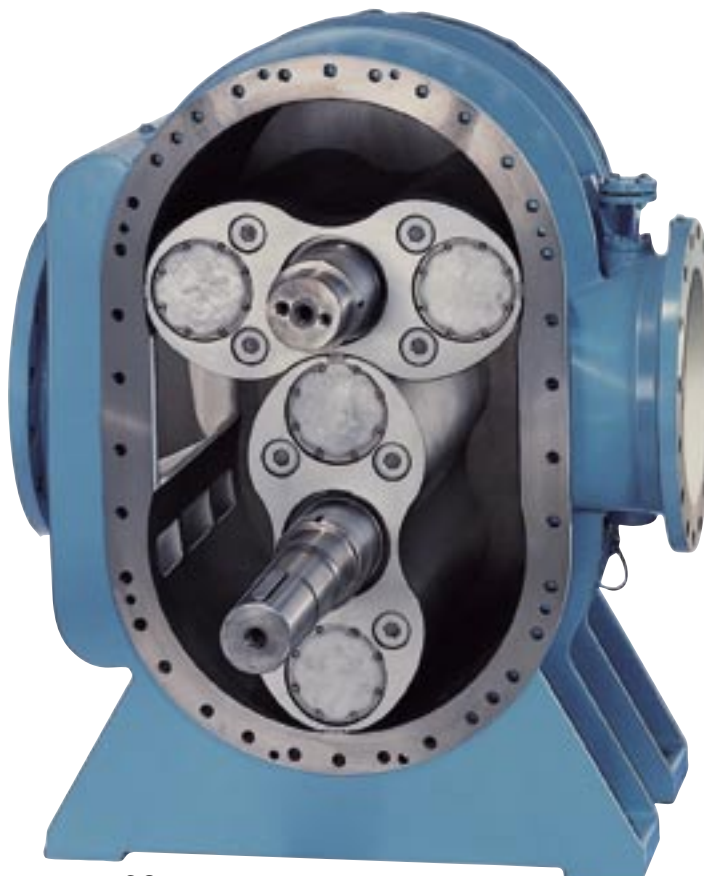

GQ 17.14 up to GQ 22.23

Aerzen Vacuum Pressure - Blowers with pre-inlet

Type GM . . . Sm

6 sizes, intake volume flow 60 up to 16.000 m³/h

for an absolute pressure at inlet of approx. 200 mbar against atmosphere

Type GM . . . Lm

3 sizes, intake volume flow 16.000 up to 50.000 m³/h

for an absolute pressure at inlet of approx. 400 mbar against atmosphere

Fields of application

Conveying of air.

In case of smaller intake volume flows of approx. 200 mbar absolute pressure at inlet against atmosphere. In case of larger intake volume flows of approx. 400 mbar absolute pressure at inlet against atmosphere.

Design

- Housing with additional third socket on suction side for pre-inlet cooling
- 3-lobe pistons
- series GM . . . Sm with lube oil supply by splash lubrication
- series GM . . . Lm with central oil circulating lubrication

Shaft sealings

The conveying chamber is sealed by means of an oil slinger in combination with 4 piston ring labyrinth seals with a central vent chamber.

The drive shaft is sealed by double radial seal rings with grease barrier.

Direction of flow

Vertical, from top to bottom.

Drive

Direct coupling with motor or via spur gear resp. narrow v-belt drive up to size 19 for all loads.

Special materials

Available in nodular graphite cast iron EN-GJS-400-15 (GGG 40) resp. EN-GJS-400-18U-LT (GGG 40.3).



Aerzen Vacuum Blowers with pre-inlet cooling

Type GMa/GMb/GMc . . . mHV

11 sizes, theoretic nominal intake volume flow 250 up to 61.000 m³/h

Fields of application

Conveying of air and neutral gases.
Vacuum from 10 mbar to approx. 300 mbar.
Max. admissible differential pressure depends on the thermal load.

Design

Housing with an additional third socket on the inlet side for the pre-inlet cooling. Housing flanges feature o-ring seals and are vacuum-tight.
Splash oil lubrication.

Shaft sealings

The conveying chamber is sealed by means of an oil slinger in combination with 4 piston ring labyrinth seals. The drive shaft is sealed by double radial seal rings with grease barrier.

Direction of flow

Vertical, from top to bottom.

Drive

Direct coupling with motor or via spur gear, narrow v-belt drive restricted to the smaller pressure differentials.

Special materials

Available in nodular graphite cast iron EN-GJS-400-15 (GGG 40) resp. EN-GJS-400-18U-LT (GGG 40.3).



Aerzen Vacuum Blowers

Type GMa/GMb/GMc . . . HV

19 sizes, theoretic nominal intake volume flow 180 up to 97.000 m³/h

Type GMa/GLa . . . V

8 sizes, theoretic nominal intake volume flow 240 up to 3.500 m³/h

Fields of application

Conveying of air and neutral gases.
Vacuum from 10⁻² mbar to approx. 200 mbar abs. only for type HV. Vacuum from 1 mbar to approx. 1.000 mbar abs. for type V.
Max. admissible differential pressure depends on the thermal load.

Design

Housing flanges feature o-ring seals and are vacuum-tight. Splash oil lubrication.

Shaft sealings

The conveying chamber is sealed by means of an oil slinger in combination with 4 piston ring labyrinth seals. The drive shaft is sealed by double radial seal rings with grease barrier.

Direction of flow (viewed onto driving shaft)

For V-blowers up to size GMa/GLa 13.8 V and for HV-blowers up to size GMb/GLa 16.13 HV alternatively vertical to the bottom or horizontal clockwise.
For HV-blowers starting from size GMb 17.15 HV vertical to the bottom.

Drive

Direct coupling with motor or via spur gear, narrow v-belt drive restricted to the smaller pressure differentials.

Special materials only for type HV

- Designs of the housing parts in nodular graphite cast iron EN-GJS-400-18U-LT (GGG 40.3)
- Rotary pistons and housing parts made of cast steel (GS-C 25) and CrNi-cast steel (1.4317 or 1.4407) are available for 5 sizes.



Information concerning Positive Displacement Blower - Units

Unit designs:

1.) DELTA BLOWER, overpressure, indoor suction

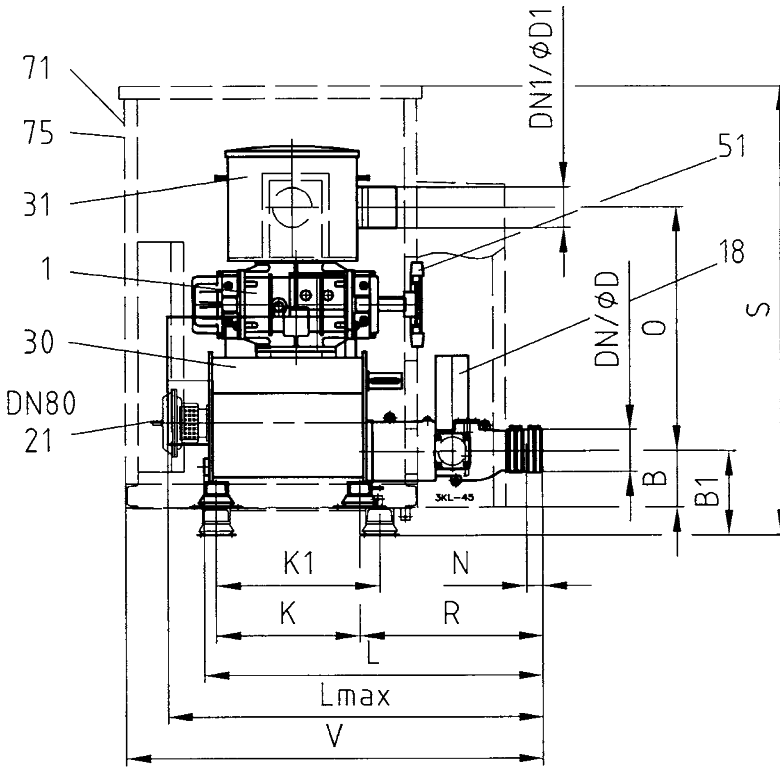

- 1 positive displacement blower
- 2 electric motor
- 4 flexible machine feet
- 7 belt drive
- 8 belt guard
- (only in case of installation without acoustic hood)
- 14 flexible pipe connection SS
- 16 flexible sleeve DS
- 18 pressure valve
- 21 start-up unloading device (accessories)
- 28 hinged motor support
- 30 base support
- 31 filter silencer
- 33 connection housing DS with integrated non-return flap
- 45 flexible hose (accessories)
- 50 acoustic hood
- 51 ventilator
- 56 shelter (accessories)
- 71 pressure gauge (accessories)
- 75 maintenance indicator (accessories)

1.) DELTA BLOWER, vacuum pressure, pipe suction

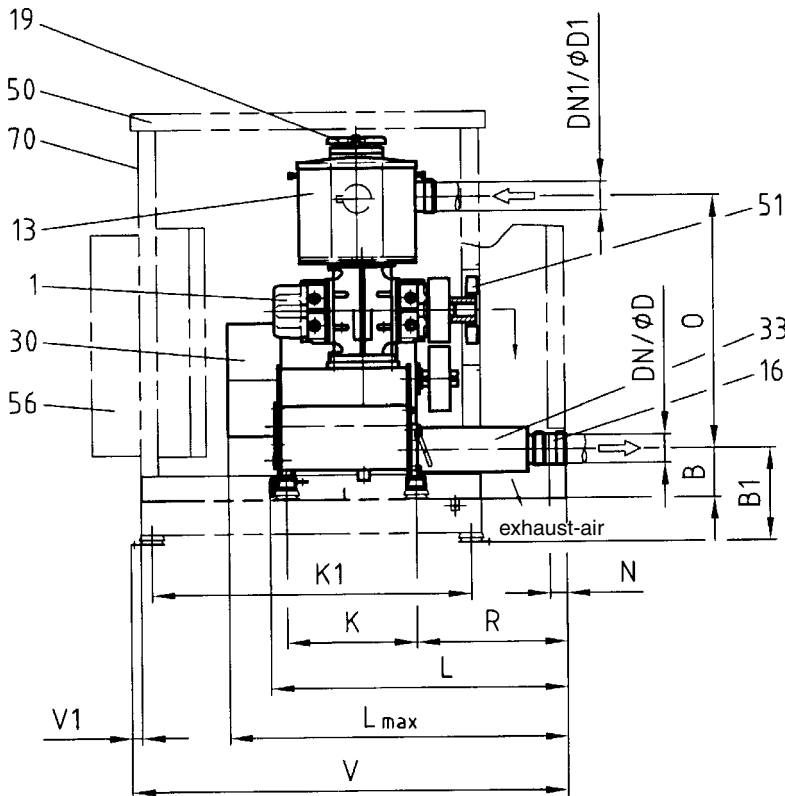

- 1 positive displacement blower
- 2 electric motor
- 4 flexible machine feet
- 7 belt drive
- 8 belt guard
- (only in case of installation without acoustic hood)
- 13 suction silencer
- 16 flexible sleeve DS
- 19 suction valve
- 23 blow-off silencer (accessories)
- 28 hinged motor support
- 30 base support
- 33 connection housing DS with integrated non-return flap
- 50 acoustic hood
- 51 ventilator
- 56 shelter (accessories)
- 70 vacuum meter (accessories)

Accessories

Our blower units normally include the standard accessories for continuous operation. The installation is effected on flat, load bearing surfaces, elevated floors or steel structures, a rigid installation on concrete foundations is also possible. In most cases the blowers are driven by a three-phase asynchronous motor and - for adjustment of the volume flow - a belt drive. Upon demand special designs as direct coupling, intermediate spur gear or special materials are also available.

Installation

In case the blower is installed at places where solid borne noise and vibrations are to be expected, the Aerzen standard version „Installation on flexible machinery mountings“ must be selected. Then it is also necessary to flexibly connect the blower package to plant piping.

When conveying air, flexible rubber sleeves connected to plant piping using clamps suffice; however, bellow type expansion joints should be used in gas and high pressure service.

Flow volume regulation

Due to forced conveyance a regulation of positive displacement blowers cannot be effected by throttling of the intake flow volume. The conveying volume is independent from the counter pressure which the blower has to overcome.

Therefore an energy efficient flow volume can only be achieved by a speed regulation although sometimes a bypass - or blow-off regulation is still selected.

The volume recirculated in by-pass operation must be cooled, as the blower will otherwise be subject to thermal overload.

Silencing

In order to reduce the intake - and discharge noises for conveying air on blowers, silencers are used at intake - and discharge side.

The type of silencer used depends on the degree of silencing required.

In case of very high sound loads additional pipe silencers can be used for suppression of the pressure pipe. The noise radiation from the machine casing is reduced by means of acoustic hoods (enclosures). Aerzen acoustic hoods can either be supplied together with the compact blower packages, or added later. It is advantageous to install large blower packages or multiple machines in separate, noise insulated rooms.

Safety measures

Aerzen Positive Displacement Blowers are protected from overload by suitably sized vacuum and/or pressure relief valves.

Where the inlet or discharge piping are closed in the absence of such protective devices, excessive vacuum or pressure builds up due to the positive displacement feature, resulting in possible damage on the blower.

However these valves do not replace the protection from the side of the plant. When conveying gases - which must not be discharged to atmosphere -, it is important to ensure that the hot gases are not recirculated directly back to the blower inlet: the recirculated gas must first be cooled. Only where blowers operate under extremely low pressure loads or during start-up it is possible to dispense with a cooler.

Check valves (Aerzen scope of supply) must be installed directly downstream of the discharge socket and the pressure relief valve to prevent the blower from running in reverse upon shut-down while operating under load.

Where several blowers operate in parallel, it is essential that check valves be installed.

Starting

Aerzen Positive Displacement Blowers can generally be started up against full system pressure in the case of direct starting motors. Where drive motors are star-delta started or internal combustion engines are used, however, care must be taken to start the blower under unloaded conditions in consideration of the starting torque characteristics of these drive machines.

Guidelines concerning inquiries

We make every effort to offer our customers the type and blower model best suited to meet the requirements of their particular application.

In order to guarantee optimal selection, the following information should always accompany the inquiry:

1. Type of medium to be conveyed

For gases, the following data is required: specific density ρ or gas constant R as well as specific heat c_p or specific heat ratio $\chi = c_p/c_v$ or the gas composition (% weight or volume).

2. Condition of medium to be conveyed

Saturated or dry. Include details on impurities, if applicable, and whether the gas is neutral or corrosive.

3. Flow capacity required (m^3/h or $m^3/min.$)

Refer to the conditions at inlet or mass flow (kg/h or $kg/min.$).

4. Intake conditions

Intake temperature t_i ($^{\circ}C$) and ambient temperature t_u ($^{\circ}C$). Absolute intake pressure P_i (bar) or altitude of site in meters above sea level.

5. Pressure rise Δp (mbar) or absolute discharge pressure $P_{abs.}$ (bar)

Where operating conditions fluctuate, both the normal and the maximum possible pressure should be indicated.





The largest Aerzen Positive Displacement Blower for the oil-free conveying and compression of 65.000 m³/h of process gas at an operating pressure of 900 mbar, in a steel plant. Length 3750 mm, width 2400 mm, height 3000 mm, weight 27,2 t.

A good address, everywhere

Federal Republic of Germany

Aerzener Maschinenfabrik GmbH · Reherweg 28
31855 Aerzen / Germany
Tel. 0 51 54 8 10
Fax 0 51 54 8 11 91

Vertriebsbüro Nord
Weißer Kamp 23
29683 Bad Fallingb. Ostel
Germany
Tel. 0 51 62 98 13-0
Fax 0 51 62 98 13 20

Vertriebsbüro Ost
Klosterstraße 8-9,
13581 Berlin / Germany
Tel. 0 30 36 75 84-6
Fax 0 30 36 75 84 80
Zweibüro:
Residenz im Park Nr. 12
04824 Beucha / Germany
Tel. 0 3 42 92 7 52 35
Fax 0 3 42 92 7 49 36

Vertriebsbüro Mitte
Erfurter Straße 2
63796 Kahl / Germany
Tel. 0 61 88 91 04-0
Fax 0 61 88 91 04 20

Vertriebsbüro Süd
Föhrenweg 1
89275 Elchingen / Germany
Tel. 0 73 08 96 08-0
Fax 0 73 08 96 08 20

Vertriebsbüro West
Taubenstraße 12
42551 Velbert / Germany
Tel. 0 20 51 98 54-0
Fax 0 20 51 98 54 18

Otto Zimmermann GmbH
Untertürkheimer Straße 9
66117 Saarbrücken
Germany
Tel. 0 6 81 5 80 07-0
Fax 0 6 81 5 80 07 43

Europe

Aerzen-France S.A.S.
10, Avenue Léon Harmel
92168 Antony Cedex
France
Tel. ++ 33 1-46 74 13 00
Fax ++ 33 1-46 66 00 61
for France, Algeria, Morocco and Tunisia

Aerzen Machines Ltd.
Aerzen House, Langston Road
Loughton, Essex, IG10 3SQ
United Kingdom
Tel. ++ 44 20 85 02 81 00
Fax ++ 44 20 85 02 81 02

Aerzen Belgium NV
Zone Guldendelle
A. De Coninckstraat 11
3070 Kortenberg / Belgium
Tel. ++ 32 2-7 57 22 78
Fax ++ 32 2-7 57 22 83
for Belgium and Luxembourg

Aerzen Nederland B.V.
Bedrijventerrein
Nieuwgraaf 124
6921 RL Duiven
The Netherlands
Tel. ++ 31 26-311-26 41
Fax ++ 31 26-311-73 69

Aerzen Iberica S.A.
c/Urogallo 13
28946 Fuenlabrada / Spain
Tel. ++ 34 91-6 42 44 50
Fax ++ 34 91-6 42 29 03

Aerzen Iberica S.A.
Rua: Sacadura Cabral, 216, 7º B
2765-349 S. João do Estoril
Portugal
Tel. ++ 3 51 21 4 68 24 66
Fax ++ 3 51 21 4 68 24 67

Aerzen Svenska AB
Östra Bangatan 20
19560 Arlandastad
Sweden
Tel. ++ 46 8-59 12 21 90
Fax ++ 46 8-59 11 72 09

Oy Ilmeco AB
Mäntytie 21
00270 Helsinki / Finland
Tel. ++ 3 58 9-4 77 21 22
Fax ++ 3 58 9-4 77 22 25

Bran & Luebbe AS
Sandviksveien 22
1363 Høvik / Norway
Tel. ++ 47 67 83 26 50
Fax ++ 47 67 83 26 51
for Norway and Iceland

Hans Buch A/S
Roskildevej 8-10
2620 Albertslund
Denmark
Tel. ++ 45 43-68 50 00
Fax ++ 45 43-68 50 50

Aerzen Austria
Handelsges. m.b.H.
Gewerbepark Tresdorf II/1
2111 Tresdorf / Austria
Tel. ++ 43 22 62 7 43 88
Fax ++ 43 22 62 7 43 99

Aerzen (Schweiz) AG
Zürcherstrasse 300
8500 Frauenfeld
Switzerland
Tel. ++ 41 52-7 25 00 60
Fax ++ 41 52-7 25 00 66
for Switzerland and Liechtenstein

Alfonso Savoia Figli s.a.s.
di Savoia Alberto & C.
Via Vittor Pisani, 28
20124 Milano / Italy
Tel. ++ 39 02-67 07 52 77
Fax ++ 39 02-67 07 50 03

MANGRINOX S.A.
14, Grevenon Str.
11855 Athens / Greece
Tel. ++ 30 210-3 42 32 01-3
Fax ++ 30 210-3 45 97 67

Cankat Mümessillik
ve Dis Ticaret Ltd. Sti
Baglarbas-Mahir Iz Cad.
No: 28, Kat. 2 D:6
34662 Uskudar / Istanbul
Turkey
Tel. ++ 90 2 16-4 74 20 67
Fax ++ 90 2 16-4 74 54 06

Aerzen Polska S.A.
Ul. Marconich 9/17
02-954 Warszawa / Poland
Tel. ++ 48 22 642 29 09
Fax ++ 48 22 642 33 08

Aerzen Slovakia S.R.O.
Mariánska 17
90031 Stupava / Slovakia
Tel. ++ 4 21 2 65 93 46 94
Fax ++ 4 21 2 65 45 71 01

Aerzen Hungária Kft.
Bécsi út 52.III./4.
1036 Budapest / Hungary
Tel. ++ 36 14 39 22 00
Fax ++ 36 14 39 19 22

Aerzen Cz s.r.o.
Namesti TGM 729/7
69002 Breclav
Czech Republik
Tel. ++ 42 05 19 32 66 57
Fax ++ 42 05 19 32 66 58

HAFI
Engineering & Consulting
Gesellschaft m.b.H.
Mühletorplatz 4-6
6800 Feldkirch / Austria
Tel. ++ 43 55 22-7 79 24-0
Fax ++ 43 55 22-7 49 38
for the remaining countries in Eastern Europe

Brasil, Mexico, USA, Canada and Asia

Aerzen do Brasil Ltda.
Rua Howard Archibaldi
Acheson Jr. N° 615
Jardim da Glória, Cep 06711
280 Cotia, SP / Brasil
Tel. ++ 55 11-46 12 40 21
Fax ++ 55 11-46 12 02 32

Aerzen México
Av. San Rafael 31
Fraccionamiento Industrial
Lerma
Lerma 52000 Estado de México (Toluca) / México
Tel. ++ 52 72 82 82 55 08
Fax ++ 52 72 82 82 51 97

Aerzen USA Corporation
645 Sands Court
Coatesville, PA 19320 / USA
Tel. ++ 1 610-3 80 02 44
Fax ++ 1 610-3 80 02 78

Aerzen Canada Blowers
Compressors Inc.
1995 Montée Labossière
Vaudreuil, Quebec J7V8P2
Canada
Tel. ++ 1 450-4 24-39 66
Fax ++ 1 450-4 24-39 85

Aerzen Asia Pte. Ltd.
38 Woodlands
Industrial Park E1
#04-01 Singapore 757700
Tel. ++ 65 6254 5080
Fax ++ 65 6254 6935

Aerzen Asia Pte. Ltd.
Room 19-G YanDang Road
200020 Shanghai / P.R.China
Tel. ++ 86 21-6258 6075
Fax ++ 86 21-6258 2946

We would be pleased to provide the addresses of our representatives in the remaining continents, upon request.



Aerzener Maschinenfabrik GmbH

Reherweg 28 · 31855 Aerzen / Germany – P.O. Box 1163 · 31849 Aerzen / Germany

Phone ++ 49 51 54 / 8 10 · Fax ++ 49 51 54 / 8 11 91 · <http://www.aerzener.com> · E-mail: info@aerzener.de